

Tyscor VS 1 Plus / VS 2



EN Installation and operating instructions

The current version of the installation and operating instructions is available in the Download Center:



<http://qr.duerdental.com/7186100001>

© DÜRR DENTAL SE

Contents



Important information

1 About this document	3
1.1 Warnings and symbols	3
1.2 Copyright information	4
2 Safety	4
2.1 Intended purpose	4
2.2 Intended use	4
2.3 Improper use	4
2.4 Systems, connection with other devices	5
2.5 General safety information	5
2.6 Specialist personnel	5
2.7 Notification requirement of serious incidents	5
2.8 Electrical safety	5
2.9 Only use original parts	6
2.10 Transport	6
2.11 Disposal	6



Product description

3 Overview	7
3.1 Scope of delivery	8
3.2 Optional items	8
3.3 Consumables	8
3.4 Wear parts and replacement parts	8
4 Technical data	9
4.1 Tyscor VS 1 Plus	9
4.2 Characteristic curves	10
4.3 Electromagnetic compatibility (EMC)	11
4.4 Tyscor VS 2	14
4.5 Characteristic curves	15
4.6 Electromagnetic compatibility (EMC)	16
4.7 Type plate	19
4.8 Evaluation of conformity	19
5 Operation	20

5.1 Separation system	20
5.2 Radial blower	21
5.3 LEDs	21
5.4 Operating modes	21
5.5 Lag time	21
5.6 Eco Stop	21



Assembly

6 Requirements	22
6.1 Installation/setup room	22
6.2 Setup options	22
6.3 Pipe materials	22
6.4 Hose materials	22
6.5 Information about electrical connections	22
6.6 Information about connecting cables	22
7 System components	23
7.1 Rinsing unit	23
7.2 Exhaust air filter / bacteria filter	23
7.3 Noise reduction	23
7.4 Flow accelerator	23
8 Installation	24
8.1 Installation and routing of hoses and pipes	24
8.2 Fitting the rinsing unit	25
8.3 Network connection	25
8.4 Electrical connections	25
8.5 PCB (main board) electrical connections	26
8.6 Upgrade/update	27
9 Commissioning	27
9.1 Monitoring the unit via the network	27



Usage

10 LEDs	29
10.1 Ready for operation	29
10.2 Eco Stop	29

- 10.3 Hose manifold start signal 29
- 10.4 Network 29
- 10.5 Fault 29
- 11 Disinfection and cleaning 30**
 - 11.1 After every treatment 30
 - 11.2 Daily after the end of treatment . 30
 - 11.3 Once or twice a week before the
midday break 30
- 12 Maintenance 31**



Troubleshooting

- 13 Tips for operators and service technicians 32**
 - 13.1 General faults 32
 - 13.2 Error messages 33
- 14 Transporting the unit 36**



Appendix

- 15 Handover record 37**
- 16 Country representatives 39**

Important information

1 About this document

These installation and operating instructions represent part of the unit.



The manufacturer and the distributor will not offer any guarantee or accept any liability for the safe operation and the safe functioning of the unit if the instructions and information in these installation and operating instructions are not complied with.

The German version of the installation and operating instructions is the original manual. All other languages are translations of the original manual. These installation and operating instructions apply to:

Tyscor VS 1 Plus

REF: 7182100100

Tyscor VS 2

REF: 7186-01

1.1 Warnings and symbols

Warnings

The warnings in this document are intended to draw your attention to possible injury to persons or damage to machinery.

The following warning symbols are used:



General warning symbol



Warning – dangerous high voltage



Warning - automatic start-up of the unit



Biohazard warning

The warnings are structured as follows:



SIGNAL WORD

Description of the type and source of danger

Here you will find the possible consequences of ignoring the warning

- Follow these measures to avoid the danger.

The signal word differentiates between four levels of danger:

- **DANGER**
Immediate danger of severe injury or death
- **WARNING**
Possible danger of severe injury or death
- **CAUTION**
Risk of minor injuries
- **NOTICE**
Risk of extensive material/property damage

Other symbols

These symbols are used in the document and on or in the unit:



Note, e.g. specific instructions regarding efficient and cost-effective use of the unit.



Wear protective gloves.



Disconnect all power from the unit.



Refer to the accompanying electronic documents.



Comply with the lower and upper temperature limits



Comply with the lower and upper humidity limits



CE labelling with the number of the notified body



Conformity mark for the United Kingdom of Great Britain and Northern Ireland, with the number of the designated authority



Authorised representative for Switzerland



Order number



Serial number



Medical device



Health Industry Bar Code (HIBC)



Manufacturer

 Fragile, handle with care

 This way up / store and transport in an upright position

 Keep dry

 Keep away from sunlight

 Stacking limits

1.2 Copyright information

All circuits, processes, names, software programs and units mentioned in this document are protected by copyright.

The Installation and Operating Instructions must not be copied or reprinted, neither in full nor in part, without written authorisation from the copyright owner.

2 Safety

The unit has been developed and designed in such a way that dangers are effectively ruled out if used in accordance with the Intended Use. Despite this, the following residual risks can remain:

- Personal injury due to incorrect use/misuse
- Personal injury due to mechanical effects
- Personal injury due to electric shock
- Personal injury due to radiation
- Personal injury due to fire
- Personal injury due to thermal effects on skin
- Personal injury due to lack of hygiene, e.g. infection

2.1 Intended purpose

The suction unit provides the dental treatment unit with vacuum and volume flow.

2.2 Intended use

Working in combination with the suction unit with treatment unit, suction handpiece and cannula, the media used in dental treatment (e.g. water, saliva, dentine and amalgam) are removed by suction for disposal.

This unit is technically suitable for the aspiration of nitrous oxide (laughing gas). However, when assembling a system for aspiration of nitrous oxide, it is important to ensure that the other components in the system are also suitable for this purpose. Those responsible for setting up the system must assess this and approve and release the system for the aspiration of nitrous oxide.

 Operation with nitrous oxide is only permitted if the exhaust air is transported from the unit to the outside of the building.

2.3 Improper use

- › Do not use this device to aspirate flammable or explosive mixtures.
- › The unit must not be used as a vacuum cleaner.
- › Do not use chemicals containing chlorine or foaming chemicals.
- › Operation in operating theatres of explosive areas is not permissible.

2.4 Systems, connection with other devices

Additional devices connected with medical electrical devices must be proven to conform with their corresponding IEC or ISO standards. All configurations must continue to comply with the standard requirements for medical systems (see IEC 60601-1).

Whoever connects additional devices to medical electrical devices automatically becomes the system configurator and is responsible for ensuring that the system corresponds with the standard requirements for systems. Local laws take priority over the requirements outlined above.

2.5 General safety information

- › Always comply with the specifications of all guidelines, laws, and other rules and regulations applicable at the site of operation for the operation of this unit.
- › Check the function and condition of the unit prior to every use.
- › Do not convert or modify the unit.
- › Comply with the specifications of the Installation and Operating Instructions.
- › The Installation and Operating Instructions must be accessible to all operators of the unit at all times.

2.6 Specialist personnel

Operation

Unit operators must use their training and knowledge to ensure safe and correct handling.

- › Instruct or have every operator instructed in the handling of the unit.

Installation and repairs

- › Have the manufacturer or a qualified company authorised by the manufacturer perform mounting, new installations, modifications, expansions and repairs.

2.7 Notification requirement of serious incidents

The operator/patient is required to report any serious incident that occurs in connection with the device to the manufacturer and to the competent authority of the Member State in which the operator and/or patient is established/resident.

2.8 Electrical safety

- › Comply with all the relevant electrical safety regulations when working on the unit.
- › Never touch the patient and unshielded plug connections on the device at the same time.
- › Replace any damaged cables or plugs immediately.

Observe the EMC rules concerning medical devices

- › The unit is intended for use in professional healthcare facilities (in accordance with IEC 60601-1-2). If the appliance is operated in another environment, potential effects on electromagnetic compatibility must be taken into account.
- › Do not operate the unit in the vicinity of HF surgical instruments or MRT equipment.
- › Maintain a minimum distance of at least 30 cm between the unit and other electronic devices.
- › Keep a minimum distance of 30 cm between the unit and mobile radio devices.
- › Note that cable lengths and cable extensions have effects on electromagnetic compatibility.



NOTICE

Negative effects on the EMC due to non-authorized accessories

- › Use only those accessories named or approved by the manufacturer.
- › Using any other accessories may result in increased electromagnetic interference emissions or the unit having reduced electromagnetic immunity, leading to an erroneous operation mode.



NOTICE

Erroneous operation mode due to use immediately adjacent to other devices or with other stacked devices

- › Do not stack the unit together with other devices.
- › If this is unavoidable, the unit and other devices should be monitored in order to ensure that they are working correctly.

2.9 Only use original parts

- › Only use accessories and optional articles named or authorised by the manufacturer.
- › Only use only original wear parts and replacement parts.



The manufacturer and distributor accept no liability for damages or injury resulting from the use of non-approved accessories, optional accessories, or from the use of non-original wear parts or replacement parts.

The use of non-approved accessories, optional accessories or non-genuine wear parts / replacement parts (e.g. mains cables) can have a negative effect in terms of electrical safety and EMC.



<http://qr.duerrdental.com/P007100155>

2.10 Transport

The original packaging provides optimum protection for the unit during transportation.

If required, the original packaging for the unit can be ordered.



The manufacturer and the distributor do not accept liability, even during the warranty period, for damage during transportation due to improper packaging.

- › Only transport the unit in its original packaging.
- › Keep the packing materials out of the reach of children.

2.11 Disposal



The unit may be contaminated. Instruct the company disposing of the waste to take the relevant safety precautions.

- › Decontaminate potentially contaminated parts before disposing of them.
- › Uncontaminated parts (e.g. electronics, plastic and metal parts etc.) should be disposed of in accordance with the local waste disposal regulations.
- › If you have any questions about the correct disposal of parts, please contact your dental trade supplier.



An overview of the waste keys for Dürr Dental products can be found in the download area:

 Product description

3 Overview

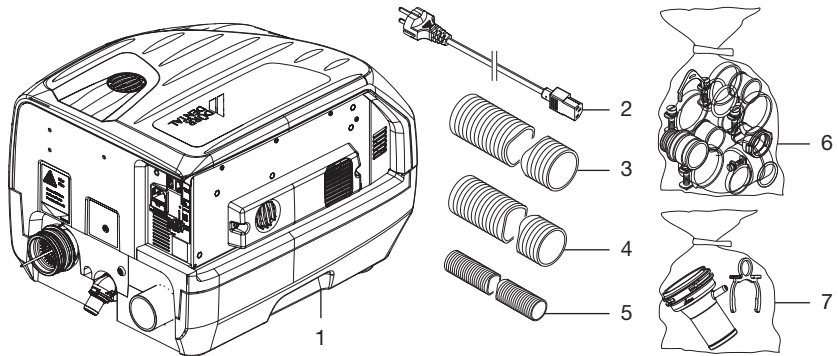

- 1 Tyscor VS 1 Plus / VS 2 combination suction unit
- 2 Mains cable with local mains plug
- 3 Hose LW 50
- 4 Hose LW 40
- 5 Waste water hose LW 20
- 6 Set of connection fittings
- 7 Hose connection kit

3.1 Scope of delivery

The following items are included in the scope of delivery (possible variations due to country-specific requirements and/or import regulations):

Tyscor VS 1 Plus 7182100100

- Combination suction unit
- Mains cable
- Hose LW 50 (1.5 m)
- Hose LW 40 (1.5 m)
- Waste water hose LW 20
- Set of connection fittings
- Hose connection kit
- OroCup
- Quick start instructions

Tyscor VS 2 7186-01

- Combination suction unit
- Mains cable
- Hose LW 50 (1.5 m)
- Hose LW 40 (1.5 m)
- Waste water hose LW 20
- Set of connection fittings
- Hose connection kit
- OroCup
- Quick start instructions

3.2 Optional items

The following optional items can be used with the device:

- Wall bracket 7130-190-00
- Bacteria filter 0705-991-50
- Noise reduction for exhaust air . . . 0730-991-00
- Rinsing unit conversion kit for
Tyscor 7186100400
- Flow accelerator 7560-992-00
- Screed frame for flow accelerator . 7560-993-00
- Console for floor-mounted installation 7130-191-00
- Noise reduction hood 7186100030
- Upgrade kit 7182100012
- Tandem kit for V/VS 2 7186100200
- Wall bracket for 2x V/VS 2 7188100015
- Bacterial filter housing 7120100000

3.3 Consumables

The following materials are consumed during operation of the device and must be ordered separately:

- Orotol plus (2.5 litre bottle) CDS110P6150
- MD 555 cleaner (2.5 litre bottle) CCS555C6150

3.4 Wear parts and replacement parts



Information about replacement parts is available from the portal for authorised specialist dealers at:
www.duerrdental.net

4 Technical data

4.1 Tyscor VS 1 Plus

Electrical data		7182100100
Rated voltage	V	230, 1~
Mains frequency	Hz	50 / 60
Nominal current	A	3.3 *
Rated power	kW	0.77 *
Fuses	A	2x T 4.0 AH / 250 V~ (IEC 60127-2)
Type of protection		IP 21
Protection class		I

* Maximum values that can be achieved in the "Boost" operating mode.

Control connection electrical data		
Output:		
Voltage	V	24
Max. current	mA	160
Input impedance	kΩ	6.9
Hi level	V	10 - 30
Lo level	V	0 - 2.5

Connections		
Suction connection (outside)	mm	Ø 40
Exhaust air connection (external)	mm	Ø 50
Drain connection, DürrConnect	mm	Ø 20

Media		
Max. number of users		1
Max. rate of flow of fluids	l/min	8
Max. suction height	cm	80

General data		
Radial blower speed (n_v) max.	rpm	24000
Separation stage speed (n_g)	rpm	2850 / 3250
Duty cycle	%	100
Dimensions (H x W x D)	cm	32 x 35.5 x 45.5
Weight	kg	11
Noise level * ca.	dB(A)	53
With optional noise reduction hood	dB(A)	48

* Noise level in accordance with ISO 3746

Network connection

LAN technology	Ethernet	
Standard	IEEE 802.3u	
Data rate	Mbit/s	100
Connector	RJ45	
Type of connection	Auto MDI-X	
Cable type	≥ CAT5	

Ambient conditions during storage and transport

Temperature	°C	-10 to +60
Relative humidity	%	< 95

Ambient conditions during operation

Temperature	°C	+10 to +40
Relative humidity	%	< 70
Altitude above mean sea level	m	< 2000

Classification

Medical Device Class (MDR)	IIa
----------------------------	-----

4.2 Characteristic curves

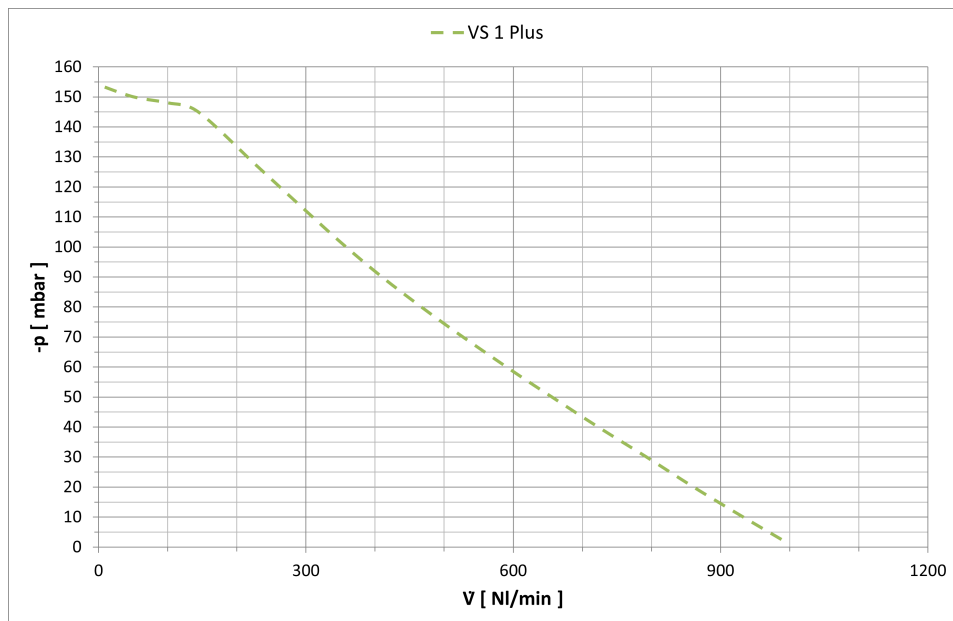

Fig. 1: Characteristic curves for: 7182100100 measured according to ISO 10637

4.3 Electromagnetic compatibility (EMC)

Electromagnetic compatibility (EMC)

Interference emission measurements

High-frequency emissions in accordance with CISPR 11	Group 1 Class B
Interference voltage at the power supply connection CISPR 11:2009+A1:2010	Compliant
Electromagnetic interference radiation CISPR 11:2009+A1:2010	Compliant
Emission of harmonics IEC 61000-3-2:2005+A1:2008+A2:2009	Compliant
Voltage changes, voltage fluctuations and flicker emissions IEC 61000-3-3:2013	Compliant

Electromagnetic compatibility (EMC)

Interference immunity measurements

Immunity to electrostatic discharge IEC 61000-4-2:2008	Compliant
Immunity to high-frequency electromagnetic fields IEC 61000-4-3:2006+A1:2007+A2:2010	Compliant
Immunity to near fields of wireless HF communication devices IEC 61000-4-3:2006+A1:2007+A2:2010	Compliant
Immunity to fast electrical transients/bursts – AC mains voltage IEC 61000-4-4:2012	Compliant
Immunity to electrical fast transients/bursts – I/O, SIP/SOP ports IEC 61000-4-4:2012	Compliant
Immunity to interference, surges IEC 61000-4-5:2005	Compliant
Immunity to conducted disturbances, induced by radio-frequency fields – AC mains voltage IEC 61000-4-6:2013	Compliant
Immunity to conducted disturbances, induced by radio-frequency fields – SIP/SOP ports IEC 61000-4-6:2013	Compliant
Immunity to power frequency magnetic fields IEC 61000-4-8:2009	Compliant
Immunity to voltage dips, short interruptions and voltage variations IEC 61000-4-11:2004	Compliant

Immunity to interference levels, near fields of wireless HF communication devices		
Radio service	Frequency band MHz	Test level V/m
TETRA 400	380 - 390	27
GMRS 460 FRS 460	430 - 470	28
LTE band 13, 17	704 - 787	9
GSM 800/900 TETRA 800 iDEN 820 CDMA 850 LTE band 5	800 - 960	28
GSM 1800 CDMA 1900 GSM 1900 DECT LTE band 1, 3, 4, 25 UMTS	1700 - 1990	28
Bluetooth WLAN 802.11 b/g/n RFID 2450 LTE band 7	2400 - 2570	28
WLAN 802.11 a/n	5100 - 5800	9

Electromagnetic compatibility (EMC)	
Interference immunity measurements on the supply input	
Immunity to fast electrical transients/bursts – AC mains voltage IEC 61000-4-4:2012 ± 2 kV 100 kHz repetition rate	Compliant
Immunity to surges, line-to-line IEC 61000-4-5:2005 ± 0.5 kV, ± 1 kV	Compliant
Immunity to surges, line-earth IEC 61000-4-5:2005 ± 0.5 kV, ± 1 kV, ± 2 kV	Compliant
Immunity to conducted disturbances, induced by radio-frequency fields – AC mains voltage IEC 61000-4-6:2013 3 V 0.15–80 MHz 6 V ISM frequency bands 0.15–80 MHz 80% AM at 1 kHz	Compliant

Electromagnetic compatibility (EMC)**Interference immunity measurements on the supply input**

Immunity to voltage dips, short interruptions and voltage variations IEC 61000-4-11:2004	Compliant
---	-----------

Electromagnetic compatibility (EMC)**Interference immunity measurements SIP/SOP**

Immunity to electrostatic discharge IEC 61000-4-2:2008 ± 8 kV contact ± 2kV, ± 4 kV, ± 8 kV, ± 15 kV air	Compliant
---	-----------

Immunity to electrical fast transients/bursts – I/O, SIP/SOP ports IEC 61000-4-4:2012 ± 1 kV 100 kHz repetition rate	Compliant
---	-----------

Immunity to impulse voltages, conductor to earth IEC 61000-4-5:2005 ± 2 kV	Compliant
--	-----------

Immunity to conducted disturbances, induced by radio-frequency fields – SIP/SOP ports IEC 61000-4-6:2013 3 V 0.15–80 MHz 6 V ISM frequency bands 0.15–80 MHz 80% AM at 1 kHz	Compliant
---	-----------

4.4 Tyscor VS 2

Electrical data		7186-01
Rated voltage	V	230, 1~
Mains frequency	Hz	50 / 60
Nominal current	A	3.3 *
Rated power	kW	0.77 *
Fuses	A	2x T 4.0 AH / 250 V~ (IEC 60127-2)
Type of protection		IP 21
Protection class		I

* Maximum values that can be achieved in the "Boost" operating mode.

Control connection electrical data		
Output:		
Voltage	V	24
Max. current	mA	160
Input impedance	kΩ	6.9
Hi level	V	10 - 30
Lo level	V	0 - 2.5

Connections		
Suction connection (outside)	mm	Ø 40
Exhaust air connection (external)	mm	Ø 50
Drain connection, DürrConnect	mm	Ø 20

Media		
Max. number of users		2
Max. rate of flow of fluids	l/min	8
Max. suction height	cm	80

General data		
Radial blower speed (n_v) max.	rpm	24000
Separation stage speed (n_s)	rpm	2850 / 3250
Duty cycle	%	100
Dimensions (H x W x D)	cm	32 x 35.5 x 45.5
Weight	kg	11
Noise level * ca.	dB(A)	55
With optional noise reduction hood	dB(A)	50

* Noise level in accordance with ISO 3746

Network connection

LAN technology	Ethernet	
Standard	IEEE 802.3u	
Data rate	Mbit/s	100
Connector	RJ45	
Type of connection	Auto MDI-X	
Cable type	≥ CAT5	

Ambient conditions during storage and transport

Temperature	°C	-10 to +60
Relative humidity	%	< 95

Ambient conditions during operation

Temperature	°C	+10 to +40
Relative humidity	%	< 70
Altitude above mean sea level	m	< 2000

Classification

Medical Device Class (MDR)	IIa
----------------------------	-----

4.5 Characteristic curves

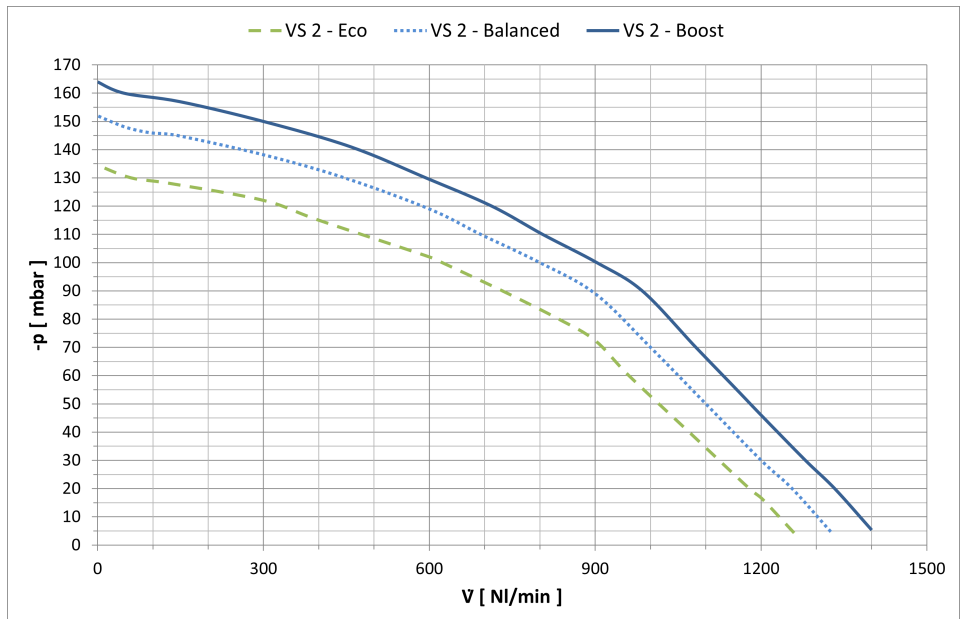

Fig. 2: Characteristic curves for: 7186-01, measured according to ISO 10637

4.6 Electromagnetic compatibility (EMC)

Electromagnetic compatibility (EMC) Interference emission measurements

High-frequency emissions in accordance with CISPR 11	Group 1 Class B
Interference voltage at the power supply connection CISPR 11:2009+A1:2010	Compliant
Electromagnetic interference radiation CISPR 11:2009+A1:2010	Compliant
Emission of harmonics IEC 61000-3-2:2005+A1:2008+A2:2009	Compliant
Voltage changes, voltage fluctuations and flicker emissions IEC 61000-3-3:2013	Compliant

Electromagnetic compatibility (EMC) Interference immunity measurements

Immunity to electrostatic discharge IEC 61000-4-2:2008	Compliant
Immunity to high-frequency electromagnetic fields IEC 61000-4-3:2006+A1:2007+A2:2010	Compliant
Immunity to near fields of wireless HF communication devices IEC 61000-4-3:2006+A1:2007+A2:2010	Compliant
Immunity to fast electrical transients/bursts – AC mains voltage IEC 61000-4-4:2012	Compliant
Immunity to electrical fast transients/bursts – I/O, SIP/SOP ports IEC 61000-4-4:2012	Compliant
Immunity to interference, surges IEC 61000-4-5:2005	Compliant
Immunity to conducted disturbances, induced by radio-frequency fields – AC mains voltage IEC 61000-4-6:2013	Compliant
Immunity to conducted disturbances, induced by radio-frequency fields – SIP/SOP ports IEC 61000-4-6:2013	Compliant
Immunity to power frequency magnetic fields IEC 61000-4-8:2009	Compliant
Immunity to voltage dips, short interruptions and voltage variations IEC 61000-4-11:2004	Compliant

Immunity to interference levels, near fields of wireless HF communication devices

Radio service	Frequency band MHz	Test level V/m
TETRA 400	380 - 390	27
GMRS 460 FRS 460	430 - 470	28
LTE band 13, 17	704 - 787	9
GSM 800/900 TETRA 800 iDEN 820 CDMA 850 LTE band 5	800 - 960	28
GSM 1800 CDMA 1900 GSM 1900 DECT LTE band 1, 3, 4, 25 UMTS	1700 - 1990	28
Bluetooth WLAN 802.11 b/g/n RFID 2450 LTE band 7	2400 - 2570	28
WLAN 802.11 a/n	5100 - 5800	9

Electromagnetic compatibility (EMC)**Interference immunity measurements on the supply input**

Immunity to fast electrical transients/bursts – AC mains voltage IEC 61000-4-4:2012 ± 2 kV 100 kHz repetition rate	Compliant
Immunity to surges, line-to-line IEC 61000-4-5:2005 ± 0.5 kV, ± 1 kV	Compliant
Immunity to surges, line-earth IEC 61000-4-5:2005 ± 0.5 kV, ± 1 kV, ± 2 kV	Compliant
Immunity to conducted disturbances, induced by radio-frequency fields – AC mains voltage IEC 61000-4-6:2013 3 V 0.15–80 MHz 6 V ISM frequency bands 0.15–80 MHz 80% AM at 1 kHz	Compliant

**Electromagnetic compatibility (EMC)
Interference immunity measurements on the supply input**

Immunity to voltage dips, short interruptions and voltage variations
IEC 61000-4-11:2004 Compliant

**Electromagnetic compatibility (EMC)
Interference immunity measurements SIP/SOP**

Immunity to electrostatic discharge
IEC 61000-4-2:2008
± 8 kV contact Compliant
± 2kV, ± 4 kV, ± 8 kV, ± 15 kV air

Immunity to electrical fast transients/bursts – I/O, SIP/SOP ports
IEC 61000-4-4:2012 Compliant
± 1 kV
100 kHz repetition rate

Immunity to impulse voltages, conductor to earth
IEC 61000-4-5:2005 Compliant
± 2 kV

Immunity to conducted disturbances, induced by radio-frequency fields – SIP/SOP ports
IEC 61000-4-6:2013 Compliant
3 V
0.15–80 MHz
6 V
ISM frequency bands
0.15–80 MHz
80% AM at 1 kHz

4.7 Type plate

The model identification plate can be found on the upper part of the housing.

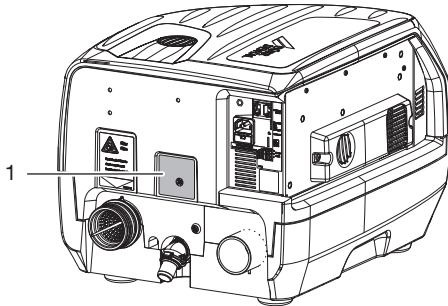

1 Type plate

4.8 Evaluation of conformity

This device has been subjected to conformity acceptance testing in accordance with the current relevant European Union guidelines. This equipment conforms to all relevant requirements.

5 Operation

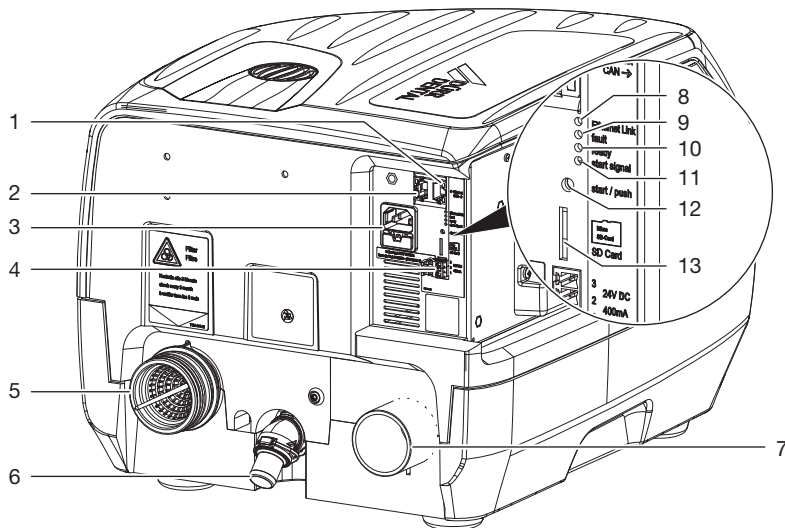

- 1 CAN bus
- 2 Network connection
- 3 Mains connection with mains fuses
- 4 Control connection
- 5 Suction connection with protective strainer
- 6 Waste water connection
- 7 Exhaust air connection
- 8 Orange LED – Ethernet
- 9 Red LED – fault in the radial blower / separation system
- 10 Green LED – ready for operation
- 11 Blue LED – start signal
- 12 Manual start button
- 13 SD card slot (Micro SD)

The VS-suction unit is used in "wet" suction systems. The unit comprises a radial blower and a separation system. The radial blower and the separation system are each driven by their own motor.

5.1 Separation system

In the separation system the aspirated fluids and the solid particles are separated from the suction air. The separation system has two stages. It consists of a cyclonic separator and a separation turbine. The suction process runs continuously.

Stage 1:

The mixture drawn in, consisting of fluids, solid particles and air, passes through the inlet connection into the device. The coarse filter holds back the solid particles. The rest of the mixture passes to the cyclonic separator, where it is set into a spiral motion. In the first stage the resulting centrifugal forces force the fluid constituents and any remaining solid particles against the outside wall of the separation chamber of the cyclonic separator. This initially creates a coarse separation of the fluid waste.

Stage 2:

The subsequent second stage comprises a separation turbine. Fine separation takes place in the separation turbine, where the remaining fluid is separated out.

The waste water pump in the separation system feeds the fluid together with the finer solid particles through the waste water system connection into the central waste water network.

5.2 Radial blower

The air that has been separated from the fluids is sucked into the radial blower. The motor in the radial blower is regulated on a demand-driven basis by the unit electronics. Afterwards, the aspirated air is passed through the exhaust air connections and out of the unit.

The antibacterial treatment of the surfaces of the radial blower with silver phosphate glass helps impede the growth of bacteria for a hygienic surface of the components.

5.3 LEDs

- The orange-coloured LED lights up when the unit is connected to the network.
- The red LED lights up when there is a fault.
- The green LED lights up continuously when the unit is ready for operation.
- The blue LED lights up when a "start" signal is present from the treatment unit.

EcoStop:

- Green LED flashes. The unit has been switched off by the EcoStop function. To switch it on, lift a suction hose up out of the hose manifold or briefly disconnect the power supply from the unit.

5.4 Operating modes

Tyscor VS 1 Plus

With Tyscor V/V/S 1 Plus there is one operating mode available.

The Tyscor V/V/S 1 Plus can supply one treatment chair. With the aid of a special upgrade, the performance can be raised to the level of a Tyscor V/V/S 2.

Tyscor VS 2

Three different operating modes are available for Tyscor V/V/S 2. They are available for selection in monitoring software installed on a PC.

The operating modes are "Balanced", "Boost" and "Eco". The different operating modes can be used to adjust the available power to the suction system (routing of lines, line lengths, layout of treatment unit etc.).

5.5 Lag time

The device will continue to run for a few seconds after the suction hose has been hung back in the manifold. The lag time ensures that the remaining fluid in the suction system can be processed. Depending on the installation, the lag time can be adjusted accordingly.

5.6 Eco Stop

The Eco Stop function is used to protect the unit if it is operated inadvertently with no flow rate or with a flow rate that is too low. If the unit is operated under these conditions without the manifold signal being actuated in the mean time, the unit will switch off automatically after a pre-defined period of time (it is possible to set this up so that it can be adjusted via the monitoring software). To switch it on, lift a suction hose up out of the hose manifold or briefly disconnect the power supply from the unit.

Assembly

6 Requirements

The unit can be installed on the same level as the surgery room or in a floor below.

 Further information can be found in our suction planning information leaflet. Order number 9000-617-03/..

6.1 Installation/setup room

The room chosen for set up must fulfil the following requirements:

- Closed, dry, well-ventilated room
- Should not be a room made for another purpose (e. g. boiler room or wet cell)
- When installing in a cabinet the inlet and outlet ventilation slots must be present; minimum free cross-section at least 120 cm².
- Forced ventilation (fan) must be provided if there is a risk that the recommended room air temperature could be exceeded. The air flow performance must be at least 2 m³/min.
- Do not cover cooling slots or openings with housing installations; ensure sufficient clearance to the openings to permit sufficient cooling.
- Mains cable plug connections must be freely accessible so they can be quickly disconnected if there is any danger.

6.2 Setup options

The following options for setting up the unit are available:

- Wall installation using a Dürr Dental wall mounting
- In a ventilated cabinet
- In a Dürr Dental noise reducing housing

6.3 Pipe materials

Only use vacuum-sealed HT-waste pipes manufactured from the following materials:

- Polypropylene (PP),
- Chlorinated polyvinyl chloride (PVC-C),
- Plasticizer-free polyvinyl chloride (PVC-U),
- Polyethylene (PE).

The following materials must not be used:

- Acrylonitrile-butadiene-styrene (ABS),
- Styrene copolymer blends (e.g. SAN + PVC).

6.4 Hose materials

For waste connections and suction lines only use the following hose types:

- Flexible spiral hoses made of PVC with integrated spiral or equivalent hoses
- Hoses that are resistant to dental disinfectants and chemicals

 Plastic hoses will display signs of ageing over time. Therefore, they should be inspected regularly and replaced as necessary.

The following types of hoses must not be used:

- Rubber hoses
- Hoses made completely of PVC
- Hoses that are not sufficiently flexible

6.5 Information about electrical connections

- › Ensure that electrical connections to the mains power supply are carried out in accordance with current valid national and local regulations and standards governing the installation of low voltage units in medical facilities.
- › Observe the current consumption of the devices that are to be connected.

6.6 Information about connecting cables

Mains supply cable

Only use the supplied mains cable to connect the device.

Control cable

Installation type	Line layout (minimum requirements)
Fixed installation	- Shielded sheathed cable (e.g. (N)YM (St)-J)

Installation type	Line layout (minimum requirements)
Flexible	<ul style="list-style-type: none"> – PVC data cable with shielded cable sheathing, as used for telecommunications and IT processing systems (e.g. type LIYCY) or – Lightweight PVC control cable with shielded cable sheathing



Connect the shielding of the cables in accordance with the regulations.

7 System components

The system components listed below are required or recommended for various procedures or for installation.

7.1 Rinsing unit

It is recommended that the suction system is equipped with a rinsing unit, e.g. in the treatment unit. The rinsing unit provides a small amount of water during aspiration. This dilutes the aspirated fluids (blood, saliva, rinsing water etc.), which can then be transported more effectively.

7.2 Exhaust air filter / bacteria filter

For hygienic reasons, we recommend the installation of a bacteria filter in the exhaust air line. If the unit is installed in the surgery and the exhaust air cannot be discharged to the outdoors, it is essential to install a bacteria filter. Depending on the type and condition of the bacteria filter, it will need to be replaced every 1-2 years at the latest.



The separation integrated in the system does not retain bacteria; this is why we recommend installing a suitable filter in the exhaust air system.

7.3 Noise reduction

If the noise level from the exhaust air vent or the flow noise generated is too high, noise reduction can be installed in the exhaust air line.

7.4 Flow accelerator

In order to keep the suction system free of deposits, a flow accelerator can be fitted in conjunction with a spittoon valve. When using a bowl rinse system, water will collect before the flow accelerator. The next time suction takes place using the large cannula, the collected fluid is transported in surges and at high speed to the suction system. This ensures automatic cleaning of the suction pipes.

8 Installation

i The actual connection can vary depending on the chosen installation option. The connection shown is only an example.

8.1 Installation and routing of hoses and pipes

- › Establish connections between the pipe system and the unit using the flexible hoses supplied. This will prevent vibrations from being transmitted to the pipe system.
- › The connection between the pipe line and unit suction connection should be kept as short as possible and straight, without bends.
- › Install the drain hoses with a downward gradient so that the waste water can drain off.
- › Waste water connections must be implemented in accordance with applicable local and national regulations.

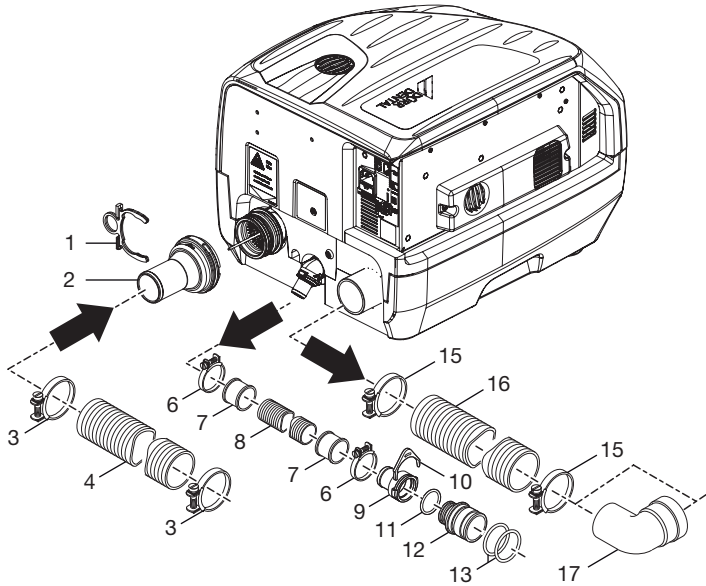

- 1 Securing ring
- 2 Straight adaptor bush
- 3 Hose clip
- 4 Suction hose \varnothing 40 mm (internal)
- 6 Hose clip \varnothing 28 mm
- 7 Hose sleeve
- 8 Waste water hose \varnothing 20 mm (internal)
- 9 Hose sleeve \varnothing 20 mm
- 10 Securing ring
- 11 O-ring 20 x 2.0
- 12 Connector \varnothing 36 mm (external)
- 13 O-ring 30 x 2
- 15 Hose clip \varnothing 55 mm
- 16 Exhaust air hose \varnothing 50 mm (internal)
- 17 Elbow DN 50

8.2 Fitting the rinsing unit

- › Screw the rinsing unit with holder firmly onto the upper part of the housing.
- › Pull off the sealing plugs from the rinse connection of the separation unit.
- › Push the rinse hose onto the rinse connection of the separation unit.
- › Connect the rinse hose to the rinsing unit.
- › Connect the hose for the water supply of the rinsing unit.
- › Connect the voltage supply of the rinsing unit on the control connection of the device to pins 2 and 3.

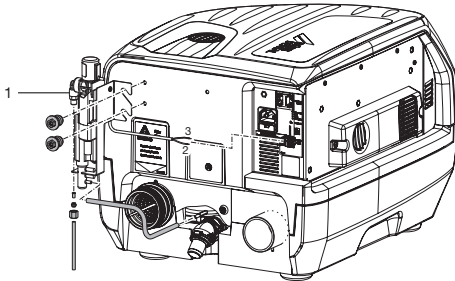

1 Rinsing unit

8.3 Network connection

Purpose of the network connection

The network connection is used to exchange information or control signals between the unit and a software installed on a computer, in order to, e. g.:

- Display parameters
- Select operating modes
- Indicate messages and error situations
- Change unit settings
- Activate test functions
- Transmit data for archiving
- Provide documents concerning the units
- › Plug in the network cable at the network connection on the unit (optional when using monitoring software).
- › Plug in the network cable at the network socket.

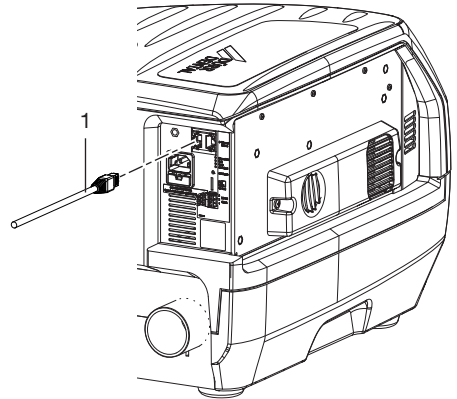

1 Network cable

8.4 Electrical connections



WARNING

Electric shock

- › The device may only be connected to a supply system with a earthed power outlet.

- › Fasten the plug socket to the control line and connect to the device.
- › Connect the mains cable to the unit and to the power outlet.

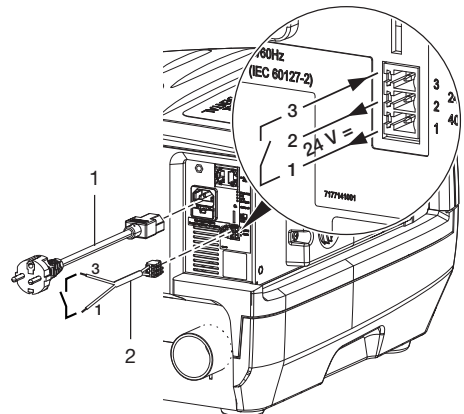

1 Mains cable with socket and country-specific mains plug
2 Control line

8.5 PCB (main board) electrical connections

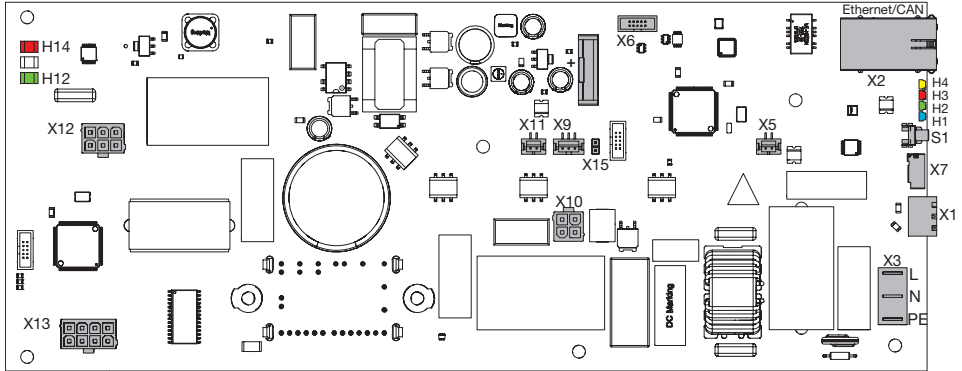

- X1 Control voltage output, 24 V DC, 400 mA, control signal input
- X2 Network connection and CAN bus
- X3 Supply voltage 230 V
- X5 Motor control fan connection 2
- X6 Service interface
- X7 SD card holder (for Micro SD)
- X9 Separation motor RPM monitor (VS only)
- X10 Separation motor supply voltage (VS only)
- X11 Motor control fan connection 1
- X12 Suction motor supply voltage
- X13 Suction motor RPM monitor
- X15 Jumper (V = closed, VS = open)
- H1 Blue LED – start signal
- H2 Green LED – ready for operation
- H3 Red LED – fault in the radial blower / separation system (VS only)
- H4 Orange LED - network connected
- H12 Green LED – radial blower temperature indicator, temperature OK
- H14 Red LED – radial blower temperature indicator, temperature too high
- S Start button

8.6 Upgrade/update

With the aid of a Micro SD card it is possible to perform an upgrade/update on the unit.

 Do not disconnect the unit from the mains during the upgrade/update.

- › Disconnect the mains plug from the unit.
- › Insert the Micro SD card into the unit.
- › Connect the mains plug.
- › Wait until the green LED for "Ready for operation" lights up again continuously.
- › Disconnect the mains plug.
- › Remove the Micro SD card from the unit.
- › Plug in the mains plug and wait until the green LED for "Ready for operation" lights up.

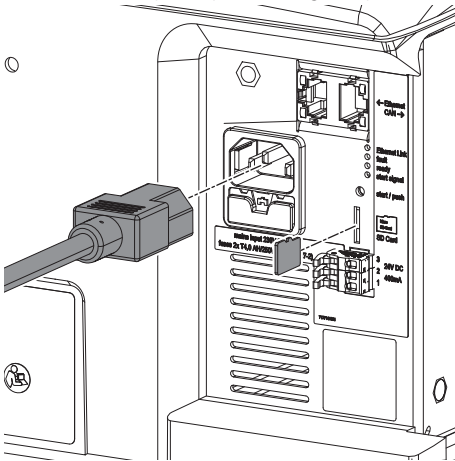

9 Commissioning

 In many countries technical medical products and electrical devices are subject to regular checks at set intervals. The owner must be instructed accordingly.



NOTICE

Interference caused by larger particles such as pieces of tooth or fillings

- › Do not operate the unit without a coarse filter

- › Check that the coarse filters are installed in the suction system (e.g. in the spittoon).
- › Turn on the unit power switch or the main surgery switch.
- › Carry out a function check of the device.
- › Check all connections for leak tightness.
- › Carry out an electrical safety check in accordance with applicable regulations (e.g. regulations concerning set up, operation and application of medical devices) and record the results as appropriate, e.g. in the technical log book.
- › Carry out and document the instruction and handover for the unit.



A sample handover report is included in the attachment.

9.1 Monitoring the unit via the network

The following requirements must be met in order to monitor the unit on the computer:

- Unit connected to the network
- Current monitoring software installed on the computer

Combining devices safely

- › Safety and essential performance features are independent of the network. The device is designed for operation independent of a network.
- › Incorrect manual configuration can lead to significant network problems. The expert knowledge of a network administrator is required for configuration.
- › The data connection utilizes part of the bandwidth of the network. Interactions with other medical devices cannot be completely excluded. Apply the IEC 80001-1 standard for risk assessment.

- › The device is not suitable for direct connection to the public internet.
- › When connecting the unit to other devices, such as a PC system, comply with the requirements set out in section 16 of IEC 60601-1 (EN 60601-1).
- › When setting up the PC system in the vicinity of the patients:
Only connect components (e.g. computer, monitor, printer) that comply with the standard IEC 60601-1 (EN 60601-1).
- › When setting up the PC system outside of the vicinity of the patients:
Connect components (e.g. computer, monitor, printer) that comply at least with the standard IEC 60950-1 (EN 60950-1) at least.

Network configuration

Various options are available for network configuration:

- ✓ Automatic configuration via DHCP (recommended).
- ✓ Automatic configuration via Auto-IP for direct connection of unit and computer.
- ✓ Manual configuration.
- › Configure the network settings of the unit using the software or, if available, the touch screen.
- › Check the firewall and release the ports, if applicable.

Network protocols and ports

Port	Purpose	Service
45123 UDP, 45124 UDP	Unit recognition and configuration	
1900 UDP	Service indicator	SSDP / UPnP
502 TCP	Device data	
514 ¹⁾ UDP	Event log data	Syslog
22 TCP, 23 TCP	Diagnosis	Telnet, SSH
123 UDP	Time	NTP

1) The port may vary depending on the configuration.

10 LEDs

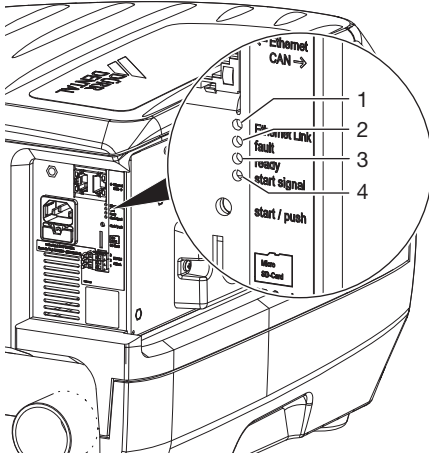

- 1 Orange LED - network connected
- 2 Red LED – fault in the radial blower / separation system (VS only)
- 3 Green LED – ready for operation
- 4 Blue LED – start signal

10.1 Ready for operation

-  Green LED lights up

10.2 Eco Stop

-  Green LED flashes
The unit has been switched off by the EcoStop function. To switch it on, lift a suction hose up out of the hose manifold or briefly disconnect the power supply from the unit.

10.3 Hose manifold start signal

-  BLUE LED illuminates
Manifold signal active and machine running.

10.4 Network

-  ORANGE display is illuminated
The machine is connected to the network.

10.5 Fault

-  RED LED illuminates
A fault is present in the radial blower or in the separation system (VS only).

11 Disinfection and cleaning



NOTICE

Device malfunctions or damage due to use of incorrect media

Guarantee claims may become invalid as a result.

- › Do not use any foaming agents such as household cleaning agents or instrument disinfectants.
- › Do not use abrasive cleaners.
- › Do not use agents containing chlorine.
- › Do not use any solvents like acetone.

As a general rule use:

- for disinfection and cleaning:
Orotol plus or Orotol ultra
- for cleaning:
MD 555 cleaner

Only these products have been tested by Dürr Dental.

When using prophy powders, water-soluble Lunos Prophy Powders are recommended in order to protect the suction systems (Dürr Dental).

11.1 After every treatment

- › Aspirate a glass of cold water through the large and the small suction hoses. Do this even if only the small suction hose was actually used during treatment.



Suction through the large suction hose causes a large amount of air to be drawn up, thereby considerably increasing the cleaning effect.

11.2 Daily after the end of treatment



After higher workloads before the midday break and in the evening

The following are required for disinfection/cleaning:

- ✓ Non-foaming disinfectant/cleaning agent that is compatible with the materials.
- ✓ Unit care system, e.g. OroCup
- › To pre-clean, suck up 2 litres of water with the care system.
- › Aspirate the disinfection/cleaning agent with the care system.

11.3 Once or twice a week before the midday break



Under harsher conditions (e.g. hard water or frequent use of prophy powders) 1x daily before the midday break

The following are required for cleaning:

- ✓ Special non-foaming detergent for suction units that is compatible with the materials.
- ✓ Unit care system, e.g. OroCup
- › To pre-clean, suck up 2 litres of water with the care system.
- › Aspirate the cleaning agent with the care system.
- › Rinse with ca. 2 l water after the application time.

12 Maintenance



All maintenance work must be performed by a qualified expert or by one of our Service Technicians.



WARNING

Infection due to contaminated unit

- › Clean and disinfect the suction before working on the unit.
- › Wear protective equipment when working (e. g. impermeable gloves, protective goggles and mouth and nose protection).



Prior to working on the unit or in case of danger, disconnect it from the mains.

Maintenance interval	Maintenance work
Every 3 months	› Check the filter at the device suction connection and clean if necessary.
Annually	› Check the waste valve for correct operation and replace it if necessary. *
Every 1-2 years	› Replace the exhaust air filter (where fitted). *

* Only to be performed by service technicians.

? Troubleshooting

13 Tips for operators and service technicians

 Any repairs exceeding routine maintenance may only be carried out by qualified personnel or our service.



WARNING

Infection due to contaminated unit

- › Clean and disinfect the suction before working on the unit.
- › Wear protective equipment when working (e. g. impermeable gloves, protective goggles and mouth and nose protection).



Prior to working on the unit or in case of danger, disconnect it from the mains.



WARNING

Electric shock due to capacitor discharge

- › Wait for the discharge time.
- › Watch for the LEDs going out.

13.1 General faults

Error	Possible cause	Remedy
Device does not start	No mains voltage	<ul style="list-style-type: none"> › Check the mains supply voltage. * › Check the fuses and replace if necessary. *
	Undervoltage	<ul style="list-style-type: none"> › Measure the supply voltage; call an electrician if necessary. *
	Control electronics defective	<ul style="list-style-type: none"> › Replace the electronics. *
The unit has been switched off, the green LED is flashing	The EcoStop function has been activated	<ul style="list-style-type: none"> › Lift up a suction hose from the hose manifold. › Briefly disconnect the power supply from the unit. › Check the switch in the hose manifold and replace as required. *

Error	Possible cause	Remedy
Water leaking from the exhaust air connection	Membrane valve defective	› Check the membrane valve at the waste water connection and if necessary clean or replace.
	Foam in turbine due to use of incorrect cleaning and disinfectant agents	› Use non-foaming cleaning and disinfectant agents.
	Build-up of condensate in the exhaust air line	› Check the pipe system; avoid over-cooling. *
Suction performance too low	Coarse filter blocked	› Clean the coarse filter at the intake connection.
	Leak in the suction pipe	› Check and if necessary establish leak-tightness of suction pipe and connections. *
	Soiling in the suction pipe	› Check the pipe system and clean it as required. *
	Soiling in the separation stage	› Check the separation stage and clean it as required. *
	Membrane valve defective	› Check the membrane valve at the waste water connection and if necessary clean or replace.
	Poor pipe routeing	› Use higher operating mode level.
No suction power	Radial blower defective	› Replace radial blower. *
	Controller defective	› Replace the controller. *
	Separation system defective	› Check the separation system and clean or replace it as required. *
Water not being pumped away	Separation system defective	› Replace separation system. *

* Only to be done by service technicians.

13.2 Error messages



If there is a network connection, the messages can be forwarded to the monitoring software. If the device is not connected to the network, the messages can be read via a terminal client (e. g. PuTTY).

Error	Possible cause	Remedy
Driver overcurrent TRIP	Radial blower motor defective	› Replace the radial blower. *

Error	Possible cause	Remedy
Speed of Sepa is low	Motor defective	› Replace the separation stage. *
	Hall sensor PCB (main board) defective	› Replace the Hall sensor PCB (main board), check the magnets in the Sepa fan. *
	Centrifuge soiled or damaged	› Check the centrifuge and clean or replace if necessary. *
Vacuum motor overheated	Radial blower motor defective	› Replace the radial blower. *
DC bus overvoltage	Control error	› Replace the electronics. *
DC bus undervoltage	Mains power supply fault	› Check the mains connection and supply voltage. *
	Machine was disconnected from the mains while running	› No action required.
	Control error	› Replace the electronics. *
No Ready Signal from vacuum machine	Control error	› Replace the electronics. *
Internal board communication disturbed	Failed firmware update	› Perform/repeat the firmware update. *
	Control error	› Replace electronics. *
Unexpected re-initialization	Firmware error	› Perform/repeat the firmware update. *
Short circuit to earth	Radial blower motor defective	› Replace radial blower. *
Vacuum motor sensor shorted	Radial blower motor defective	› Replace radial blower. *
Vacuum motor sensor open circuit	Radial blower motor defective	› Replace radial blower. *
	Motor cable not correctly connected to the control board	› Check the plug connection. *
Firmware mismatch	Different firmware versions on the two processors after a firmware update	› Perform/repeat the firmware update. *
Speed Feedback Failure	Motor speed detection defective	› Replace radial blower. *
MC Lib failure	Control error	› Replace the electronics. *
CPU overheated	Insufficient ventilation or poor set-up conditions	› Check the setup conditions, ensure adequate ventilation.
	Fan in the foam housing soiled	› Clean the fan and ventilation slots for supply and exhaust air. *
	Fan in foam housing defective	› Replace the fan. *
	Control electronics defective	› Replace electronics. *

Error	Possible cause	Remedy
Power Pack overheated	Insufficient ventilation or poor set-up conditions	› Check the setup conditions, ensure adequate ventilation.
	Fan on the electronics housing soiled	› Remove the cover on the electronics housing, clean the fan and heat sink. *
	Fan on electronics housing defective	› Replace the fan. *
	Control electronics defective	› Replace electronics. *
Eco Stop. Switch start signal off and on again to restart	Unit has been switched on unintentionally for too long.	› Check whether all suction hoses are correctly hung up. › Briefly disconnect the unit from the mains. › Check whether a permanent start signal is present at the unit. * › Check the control cable. *

* Only to be done by service technicians.

14 Transporting the unit



WARNING

Infection due to contaminated unit

- › Disinfect the unit before transport.
- › Close all media connections.



Wear protective equipment to avoid any risk of infection (e.g. liquid-tight protective gloves, protective goggles, face mask).

- › Prior to disassembly, clean and disinfect the suction unit and the unit via aspiration of a suitable disinfectant approved by the manufacturer.
- › Disinfect a defective unit using a suitable surface disinfection agent.
- › Seal all connections with sealing caps.
- › Pack the unit securely in preparation for transport.

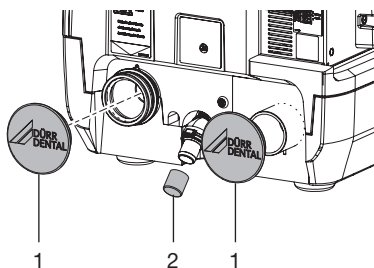

- 1 Sealing cap
(order number 7186100070)
- 2 Waste water connection sealing cap
(order number 9000-412-98)
- x Sealing cap set
(order number 7186100071)

 Appendix

15 Handover record

This document confirms that a qualified handover of the medical device has taken place and that appropriate instructions have been provided for it. This must be carried out by a qualified adviser for the medical device, who will instruct you in the proper handling and operation of the medical device.

Product name	Order number (REF)	Serial number (SN)

- Visual inspection of the packaging for any damage
- Unpacking the medical device and checking for damage
- Confirmation of the completeness of the delivery
- Instruction in the proper handling and operation of the medical device based on the operating instructions

Notes:

Name of person receiving instruction:**Signature:**

Name and address of the qualified adviser for the medical device:

Date of handover:**Signature of the qualified adviser for the medical device:**

--	--

16 Country representatives

Country	Address
CN	<p>备案人/生产企业：DÜRR DENTAL SE 德国迪珥齿科股份公司 住所/生产地址：Höpfigheimer Str. 17, 74321 Bietigheim-Bissingen, Germany 联系方式： 电话：+ 49 7142 705-0 邮箱：info@duerrdental.com 网址：www.duerrdental.com</p> <p>代理人/售后服务单位：迪珥医疗器械（上海）有限公司 住所：上海市长宁区天山路 641 号 2 号楼 (20 幢) 303 室 联系方式： 电话：+ 86 21 6381 0270 传真：+ 86 21 6381 0290 邮箱：info@duerr.cn 网址：http://www.duerrdental.com</p>



Hersteller / Manufacturer:

DÜRR DENTAL SE
Höpfigheimer Str. 17
74321 Bietigheim-Bissingen
Germany
Fon: +49 7142 705-0
www.duerrdental.com
info@duerrdental.com

